

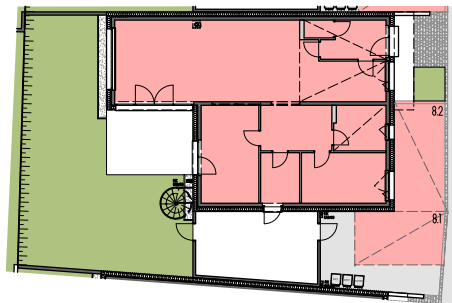









HAUS 8 GARTENFL.  
(INKL. ALLE BEF. FLÄCHEN)  
NFL = 112,34 m<sup>2</sup>

0 1 2 3 4 5 m  
MASSSTAB 1:100

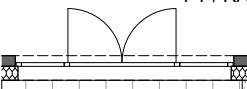

5 10  
MASSSTAB 1:300

LEGENDE :

-  PARKETT
-  FLIESEN - FSZ
-  GARTEN
-  PLATTENBELAG
- ZL ← ( ) ZULUFT
- AL → ( ) ABLUFT
- PT / RA ( ) PUTZTÜR/  
RAUCHROHRANSCHLUSS
-  DREH/KIPP TERRASSENTÜR  
2 FLÜGELIG MIT SEITL. FIXTEIL
-  EINGANGSTÜR MIT SEITL.  
FIXTEIL
-  DREH/KIPP  
FENSTER
-  FRANZ.  
FENSTER



REIHENHAUS	08
GRUNDFLÄCHE	360,21 m <sup>2</sup>
WOHNNUTZFLÄCHE	124,01 m <sup>2</sup>
GARTEN (BEF. FL.+GRÜNFL.)	112,34 m <sup>2</sup>
LAGERRAUM	26,18 m <sup>2</sup>